

Product Information:

- Architectural Rainscreen Panel for interior or exterior applications
- Available in FR (Fire Resistant mineral core) standard and PE (Polyethylene core) upon request
- Available in 4mm and 6mm thickness
also available in Copper, Stainless Steel and Zinc
- 0.2mm face and backer sheet standard in 300(series alloy)
- Finishes: Pro finish 500 (PPG Industries Duranar) Standard, Mica and Metallic with clear coat
- Maximum fabricated panel is 60" x 192"
- Matching flat sheets available in 48" x 120" x .040 Aluminum

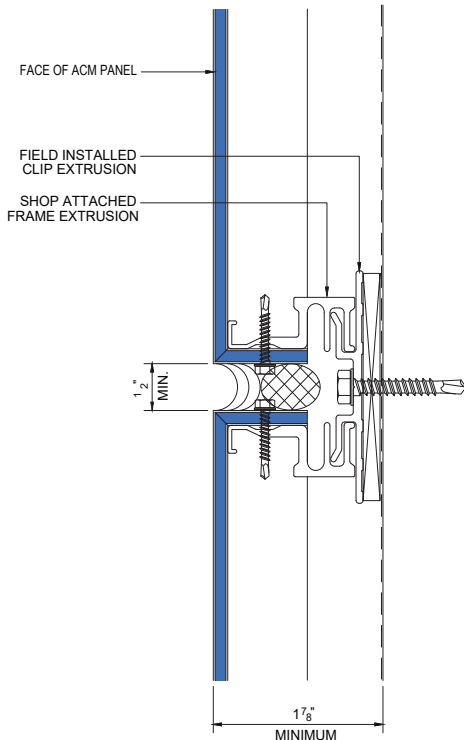

ACM Series A2000 Wet System



Technical Overview:

Product Testing: Fire and Physical Performance

- ASTM E-84 • ASTM D-1929 • ASTM E-8
- ASTM C-297 • ASTM D-635 • ASTM D-1781

PPG paint warranty- 20 years standard (inquire for added duration)